



staron®

Solid Surfaces

BEAUTY, VERSATILITY,
FUNCTIONALITY

STARON.UK.COM



Staron is a unique blend of acrylic polymer, natural minerals and pigments that is flexible, durable and visually breathtaking.



BEAUTY, VERSATILITY, FUNCTIONALITY

IMAGINE A MATERIAL THAT CAN MORPH INTO A MYRIAD OF SHAPES THAT CAN FORM LONG, STYLISH SWEEPS, SEXY CURVES OR SHARP ANGLES. A PRODUCT WHOSE APPLICATIONS ARE LIMITLESS, A TRULY CONTEMPORARY MATERIAL FOR DESIGNERS WHO CRAVE A NEW WAY TO BRING LIFE TO THEIR CONCEPTS.



THE BEAUTY OF
STARON IS THAT
YOU CAN DESIGN
YOUR OWN
UNIQUE PROFILE

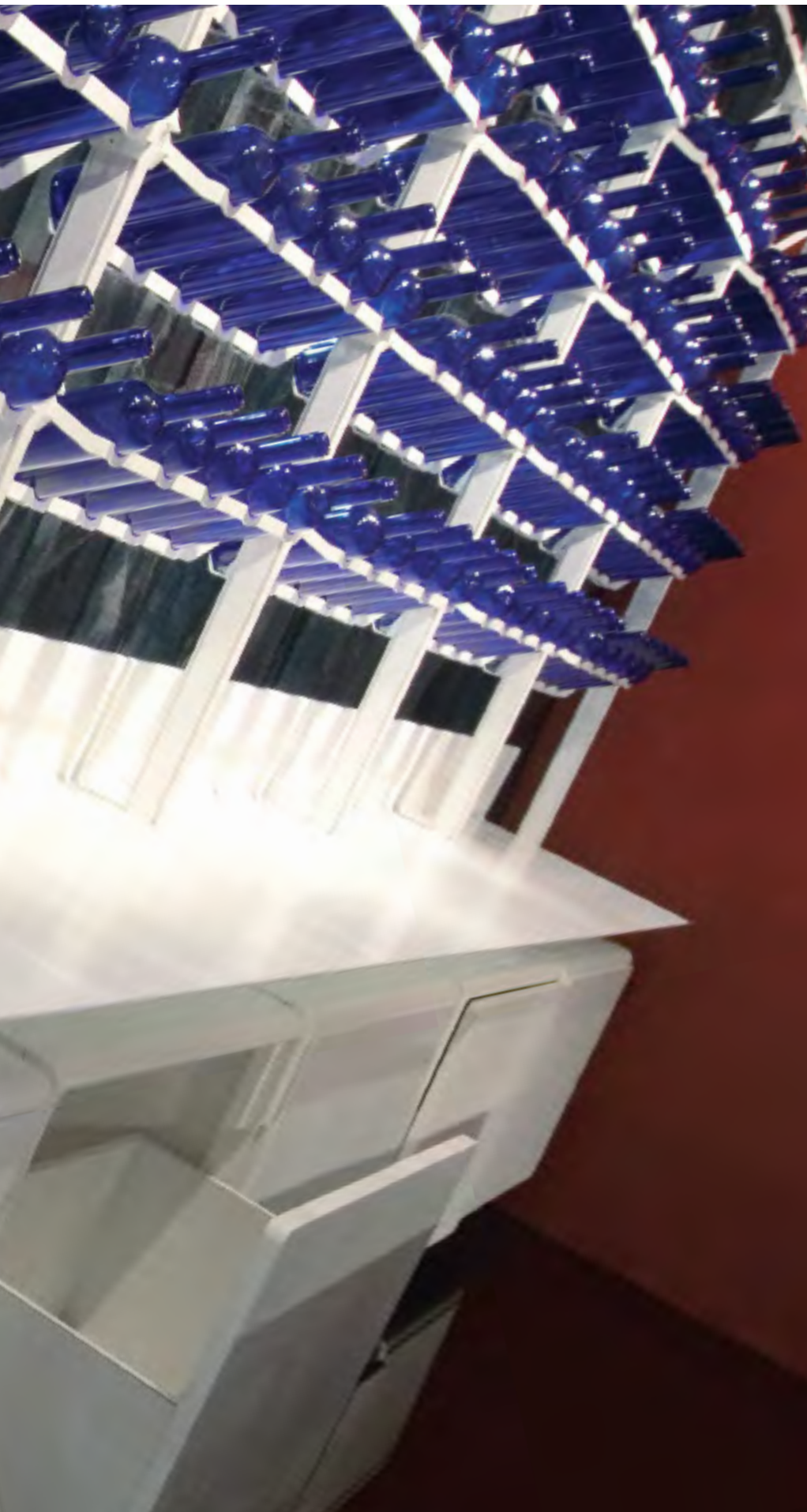

staron[®]
Solid Surfaces

BEAUTY

SOLID SURFACE

Staron's colourful designs are not just skin deep... they run consistently and throughout its thickness.

This solid colour effect allows Staron to follow the contours of a shape without the need for joints or separately applied edges. Machined areas such as cut outs, edge profiles and engraving will continue to show the surface design.

Because Staron adhesive, sheets, bowls and sinks are all made of the same polymer, the seams are fused together with joints that are inconspicuous. This creates a naturally flowing, one piece appearance that is not only smart, but is also hygienic, completely waterproof and easy to clean.

UPSTANDS AND SPLASHBACKS

Colour matched Staron upstands or tall splashbacks are the perfect way to protect walls from spills and splashes and completes a sleek seamless look.

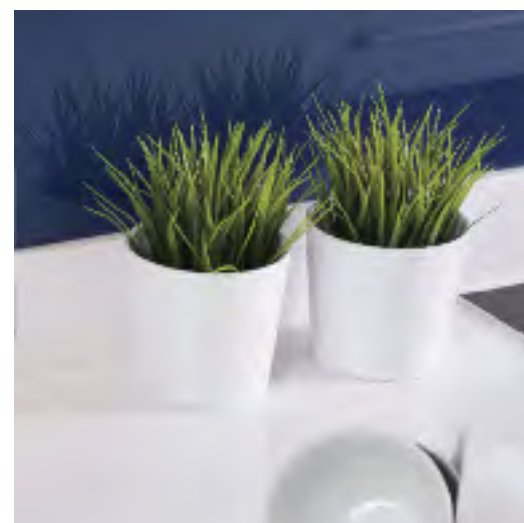

staron®
Solid Surfaces

THE INFINITE
SHAPES OF STARON
CAN BE USED FOR
BOTH PRACTICAL
AND AESTHETIC
DESIGN CRITERIA

lämml_i_architektur



VERSATILITY

ENDLESS SHAPES

Thermo-plastic formability means Staron's applications are limitless: it can be heat formed to fit into narrow spaces or sculpted into dramatic curves and exciting shapes. And of course the shapes and curves are completely seamless! No loss of structure or any other physical properties of Staron are compromised by this thermoforming process and the resultant shapes and curves are completely stable after the process is complete.

TRANSLUCENCY AND SUBLIMATION

Staron's unique translucent qualities when backlit can create an eye-catching focal point and help you make the right first impression with a stunning lobby area or reception desk to woo new clients.

How about personalising your Staron by placing an image or logo within the surface? Create truly unique colours and designs through the technique of sublimation – a high temperature printing process whereby special dyes permeate the surface of the Staron. Unlike other surface printing methods, the resulting design is embedded into the Staron surface and therefore retains its colour and can be sanded or polished depending on surface texture requirements. Sublimation is ideal for corporate branding opportunities and to create long lasting, individual patterns for worksurfaces and wall panels.



FUNCTIONALITY

WATERPROOF AND HYGIENIC

Staron is 100% waterproof and because it is not a multi-layered product, it will not delaminate. Staron is chemically inert and is a completely safe surface. It is easy to clean and 100% non-porous, so harmful germs are prevented from being absorbed within the surface. Also, because Staron has smooth inconspicuous seams, there are no unsightly joints for dangerous bacteria to develop. Staron is certified NSF-51 food-safe, which makes it a perfect surface for food preparation.

EASY TO CLEAN AND MAINTAIN

A damp cloth and mild detergent are all that is needed to deal with everyday spills and to keep Staron surfaces looking good.

FIRE RETARDANT

Staron achieves Euro class B with many of its designs and Euro class C with all the rest. This level of fire retardancy is exceptional and has qualified Staron to be used in high traffic transport areas where the fire regulations are obviously some of the most stringent.

STRONG AND DURABLE

Staron surfaces are so well produced and tough, they have passed the ISO 16933 based bomb blast test and is classed as compliant with the stringent requirements of the UK's Department for Transport's AISAD document for the wall panelling systems used in UK airports.

REPARABILITY

One of Staron's many fine features is its capacity to be repaired. In the rare event that a surface should suffer a serious impact, damaged areas can be brought back to life to look as good as new.





STARON SOLID
SURFACES WILL
NOT BLEACH OR
FADE IN SUNLIGHT





APPLICATIONS & LOCATIONS

STARON CAN BE USED WITHIN ALL COMMERCIAL
AND DOMESTIC CONSTRUCTION PROJECTS.
ON THE FOLLOWING PAGES, WE SHOW TANGIBLE
EXAMPLES OF SOME OF THE LOCATIONS AND APPLICATIONS
WHERE STARON HAS BEEN SUCCESSFULLY SPECIFIED.

HOTEL AND LEISURE

For hotel bedrooms with allure, Staron creates enticing interiors which will make your guests want to return again and again. Choose moody, dark colours for boudoir chic, or lighter shades for minimalist elegance. Whichever Staron you choose, your hotel bedroom will be easy to clean and continue to look good, despite a constant stream of guests and their luggage, thanks to Staron's excellent impact resistance.

Staron is also an ideal material for creating cutting-edge student villages for the 21st century with contemporary dormitories and stylish communal areas, ideal for socialising, relaxing and studying. Staron surfaces cannot fail to impress tomorrow's students and will prove to be a smart investment thanks to its practical, hardwearing qualities.



STARON WILL
CREATE ENTICING
INTERIORS
WITH MINIMALIST
ELEGANCE

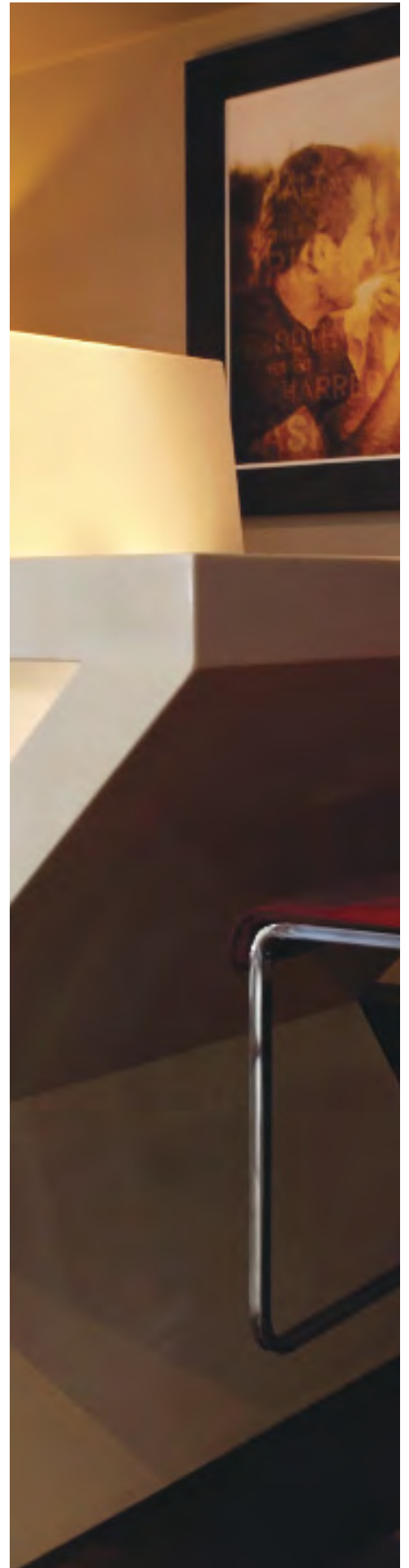



GASTRONOMY

Whether you are designing a fast food counter, chic city delicatessen or up-market eatery, Staron provides a visually striking and hygienically safe surface on which to prepare and serve food.

Heat resistant to 130°C, Staron is certified NSF-51 food-safe, 100% waterproof and fire retardant to Euro class B on a wide range of designs. For the ultimate in integration, Staron basins are available in a range of sizes and styles to complete the fluid lines. Add some Staron thermoformability as seen in these images and you can create a truly unique, but completely practical and easy to maintain environment.



STARON IS
A HYGIENICALLY
SAFE SURFACE
IDEAL FOR FOOD
PREPARATION

HEALTHCARE AND LABORATORIES

Where health and safety requirements are stringent, Staron is ahead of the field. Today's healthcare practitioners know how important hygiene is to patients, staff and visitors. A non-porous, inert surface which cannot harbour germs, Staron meets the rigorous demands of today's medical and clinical research professions.

A one-piece Staron worksurface with an integrated sink provides the ultimate hygienic work station, where it is almost impossible for mould and mildew to form.

Seamless wall cladding is another perfect use of Staron to create a hygienic, easy to clean environment for modern health care applications.

In hospitals, care homes, dental surgeries and other healthcare centres, Staron surfaces provide worry-free work stations, benches, desks and reception areas, even in the most demanding of environments.

Today's laboratory surfaces must be able to withstand moisture, staining, chemicals and impact - more importantly, they must be sterile.

Laboratory stains such as iodine can be easily removed with mild abrasive cleaners and scouring pads. Even harsh chemicals including acids and solvents will not harm Staron, provided they are not left in contact with the surface for any length of time. Integrated sinks within the worksurfaces ensure germs and mould are kept at bay.



STARON SURFACES
ARE TECHNICALLY
BRILLIANT

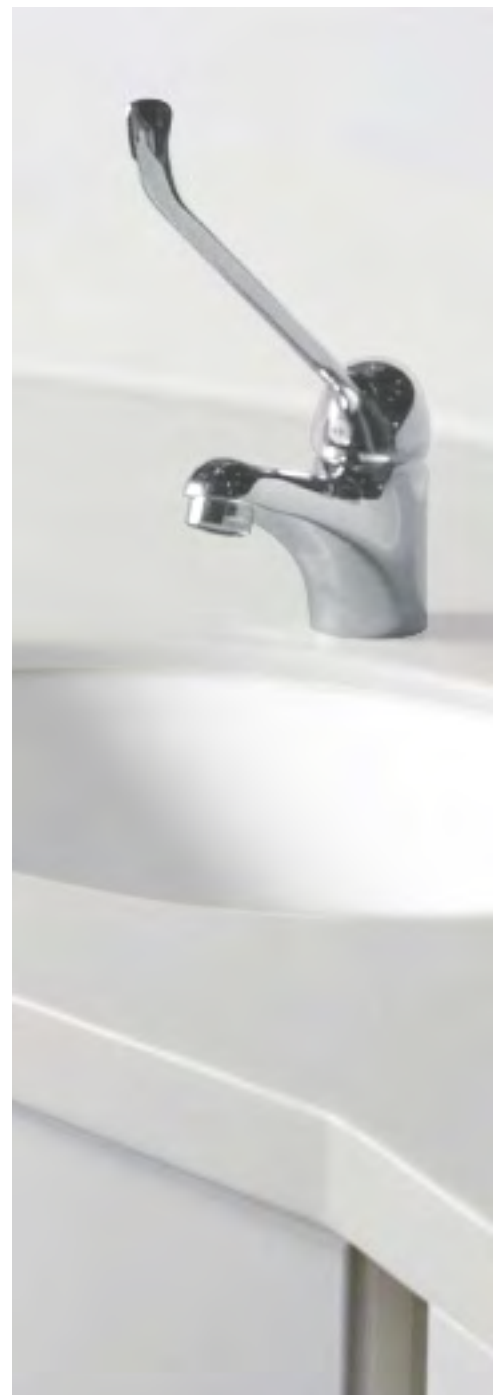



FAÇADE CLADDING

Staron's toughness, UV stability, stain and chemical resistance and temperature tolerance makes it a surface that can be specified with the correct installation fittings for exterior as well as interior applications.



staron®
Solid Surfaces

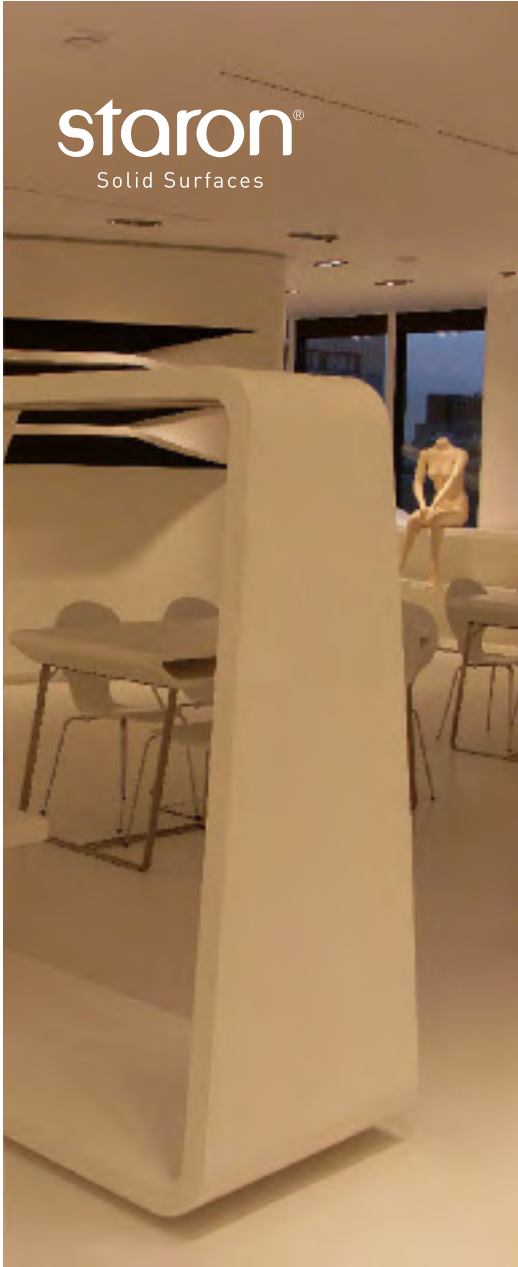

RETAIL

Life can be tough on the high street and creating the right environment for consumers is key to the success of any store. Staron's colours and thermoformability can give you the tools you need to create exciting, practical shopping environments. Consumer products can be enticingly displayed to great effect within a Staron open cabinet or on a shelf or pedestal, especially when they are combined with clever lighting effects.



STARON CREATES
A BEAUTIFUL AND
PRACTICAL RETAIL
EXPERIENCE



TRANSPORT

Staron has achieved the stringent requirements of the Euro Class B fire classification and is UK airport AISAD blast test compliant. These fantastic performance characteristics allow Staron to be specified with safety into the mass – transit areas of the UK's transport industry. Not only fire – proof and literally bomb – proof, but also ultra violet and water – proof: Staron is a first class material.

A constant flow of people, grubby finger marks and everyday wear and tear demand a highly durable surface material that is easy to clean.

In airports, railway carriages, ticketing offices, station forecourts and even yacht interiors, Staron surfaces create a welcoming and practical environment for today's well-travelled public.





STARON IS
NOT ONLY FIRE
RESISTANT BUT,
EASY TO CLEAN
AND DURABLE

WETROOMS, CUBICLES AND CHANGING AREAS

Staron is resilient, non-porous and smooth. With no visible joins, mould and bacteria have no chance of survival in a wet area. These qualities make Staron ideal for clean, attractive, germ-free changing rooms, gyms, swimming pools, hotels and spas. Shower, changing and toilet partitions and cubicles can be formed from Staron, which will thrive in steamy surroundings, repelling water and standing up to wear and tear. Flowing designs can be lovingly realised with integrated basins imparting a continuous surface which is easy to clean and maintain. Choose pure white for minimalist chic, or any of the impressive range of over 80 colours and finishes.



STARON IS
SEAMLESS AND
100% WATERPROOF





STARON IS A HIGH
QUALITY MATERIAL
WHICH CAN
SUPPORT FRESH
NEW DESIGNS

SCHOOLS AND FURTHER EDUCATION

Inspire future generations by using Staron in classrooms, science labs, changing rooms and sports facilities - in fact any educational environment where surface materials that will last for decades are of primary importance.

With plans for more Academies and Free Schools in the pipeline, Staron offers a high quality material which can support fresh new designs suitable for these new 'super schools'. Vitalise pupils with Staron's poppy reds and sunflower yellows, or use calming neutrals for quiet places and thinking spaces.

Staron holds both the Greenguard Children and Schools Certification and an Indoor Air Quality Certificate for its low emissions which makes it the ideal material for use in all educational applications.





staron®
Solid Surfaces

DOMESTIC KITCHENS AND BATHROOMS

Staron's certification as NSF-51 food-safe and 100% waterproof qualities combined with imperceptible seams, makes it an ideal material for modern kitchens and bathrooms.

Staron also brings a unique flair to any kitchen or bathroom. Minimalist designs, such as those shown, convey a real beauty and instill a sense of quality and outstanding craftsmanship. With a comprehensive choice of colours and decors to suit the most discerning of palettes, Staron can give you the flexibility to create the style you want for the perfect kitchen or bathroom.

STARON IS NOT
ONLY STYLISH
BUT COMPLETELY
HYGIENIC

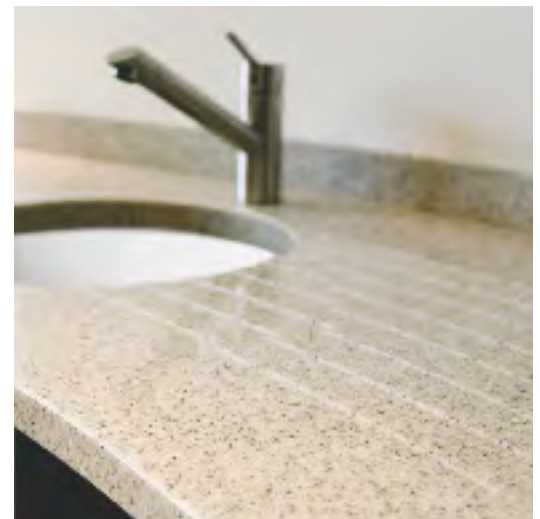

CASE STUDY – NATURAL HISTORY MUSEUM

After visiting Blackheath's Staron exhibition stand at the 100 Percent Design Show, the Natural History Museum's in-house designer, Gemma Smith, worked with us and award-winning design, build and fit out company, Paragon Creative.

York-based Paragon Creative was commissioned to create a plinth which would house the most complete Stegosaurus skeleton in the world. The dinosaur, on display at London's Natural History Museum, was discovered in 2003 in Wyoming US and existed around 150 million years ago.

In total, the armature and skeleton weighs 900kg. Paragon's Production Design and Solid Surface facility designed an internal independent steel frame inside the outer plinth, which sits on bespoke shock absorbent feet. The outer plinth then surrounds and covers this inner plinth with no contact what so ever. This outer plinth is covered in two colours of Staron Solid Surface (Sanded Tundra and Sanded Stratus). Each layer has been CNC cut and fabricated to exact dimensions, which keeps the contours precise and even, and ensures the structure of the plinth is strong enough to carry the weight of the Stegosaurus. The whole plinth and Armature was then erected in Paragon's Solid Surface workshop in York before being dismantled and shipped down to the Natural History Museum and installed on site behind tight security.

Paragon also built a Staron Solid Surface interpretation table, incorporating replicas of the dinosaur supplied by Propshop and Graphics and AV by the Natural History Museum.



The design brief was a tremendous challenge. The plinth had to support the armature for the Stegosaurus without actually touching it, eliminating the risk of vibration or impact movement.

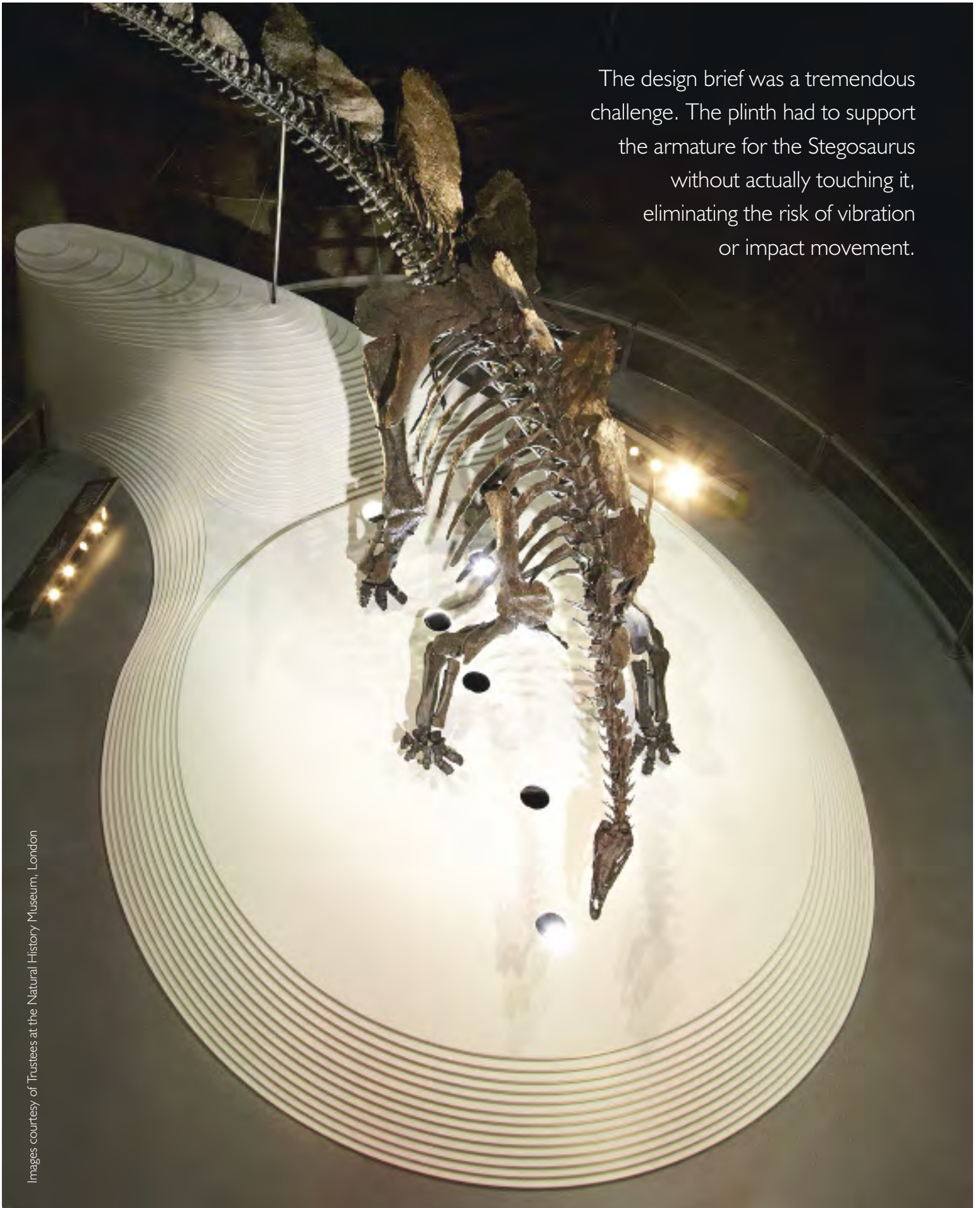

CASE STUDY – MERTHYR TYDFIL COLLEGE

Merthyr Tydfil College needed reception counters for the main entrance and each department entrance, as well as food service counters and cash desks for the coffee shop and refectory areas.

The Staron design: Tempest Zenith was chosen as it best reflected the appearance of the shale rock that makes up a large part of the geology of the Merthyr Tydfil area.

Each of the reception desks were machined with a CNC router to allow Bright White Staron to be inlaid flush into the Zenith design to provide location signage in both Welsh and English. This work, while intricate, provided bold and clear signs that are easily cleaned and will stay looking as good as new.

The project architect was Boyes Rees of Cardiff and the main contractor was Interserve. The reception counters were manufactured by Limebright of Newport Gwent and the service and coffee shop surfaces were manufactured by Counterline of Liverpool.

Staron's design features were utilised to their full; hygienic and easy to clean seamless surfaces with strong construction and great looks!



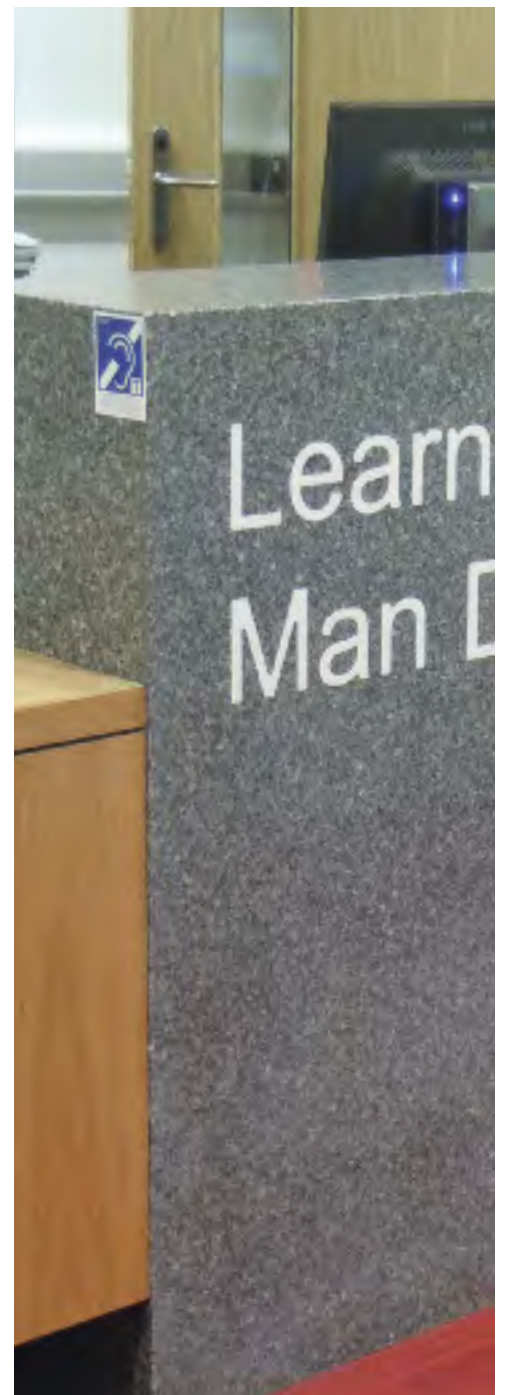





SINKS AND DÉCORS

BLACKHEATH, STARON'S EXCLUSIVE UK AND IRELAND DISTRIBUTOR, HOLDS OVER 80 DESIGNS IN STOCK IN A CENTRALLY LOCATED WAREHOUSE FACILITY. THIS HUGE STOCKHOLDING IS COMPLEMENTED BY A WIDE RANGE OF SINKS SPECIFICALLY DESIGNED FOR USE WITH STARON SOLID SURFACING SHEET MATERIALS.

SOLID SURFACE SINKS AND BOWLS

The solid surface sinks and bowls fully integrate and have no open joints or seams when installed into Staron solid surfaces. This means you have a completely hygienic and easy to maintain surface and sink or bowl which flow together giving you a sensational look.

MOUNTING OPTIONS

SEAM MOUNT

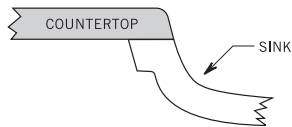

UNDERMOUNT

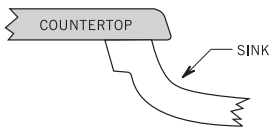

ANGLED MOUNT

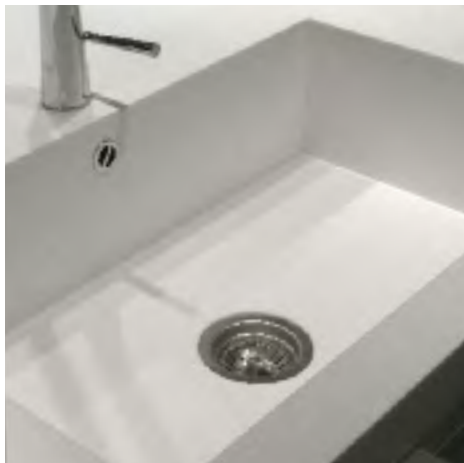
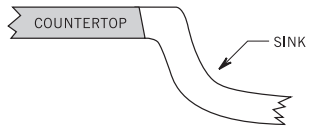

A1121
Bright White

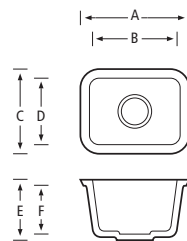

A	416mm	D	266mm
B	356mm	E	180mm
C	326mm	F	165mm



A1181
Bright White

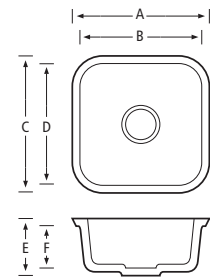

A	460mm	D	400mm
B	400mm	E	225mm
C	460mm	F	208mm



A1231
Bright White

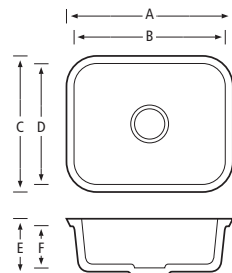

A	592mm	D	422mm
B	532mm	E	202mm
C	482mm	F	187mm



A3181
Bright White

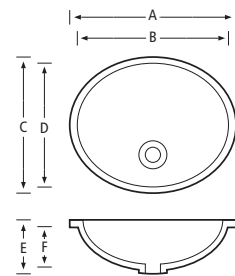

A	462mm	D	336mm
B	422mm	E	156mm
C	376mm	F	139mm

CAST SINKS AND BOWLS



A1131
Bright White

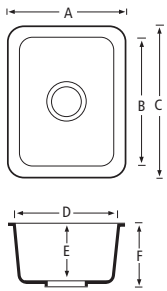

A 341mm	D 281mm
B 400mm	E 133mm
C 460mm	F 148mm



A2341
Bright White

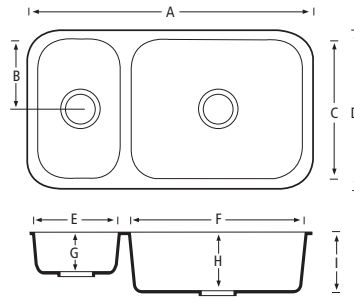

A 886mm	F 533mm
B 213mm	G 127mm
C 426mm	H 191mm
D 486mm	I 206mm
E 254mm	



A2311
Bright White

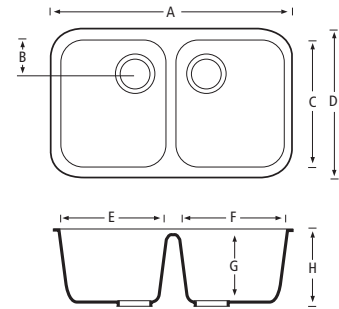

A 794mm	E 348mm
B 110mm	F 348mm
C 421mm	G 235mm
D 481mm	H 250mm



A3211
Bright White

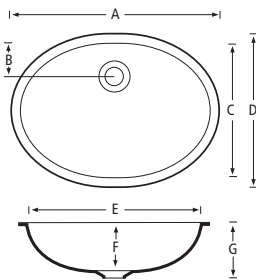

A 548mm	E 508mm
B 66mm	F 156mm
C 356mm	G 173mm
D 396mm	



A3201
Bright White

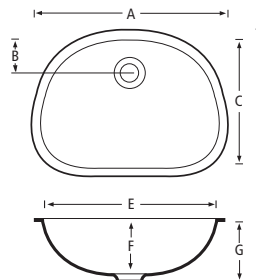

A 517mm	E 477mm
B 86mm	F 140mm
C 346mm	G 157mm
D 386mm	

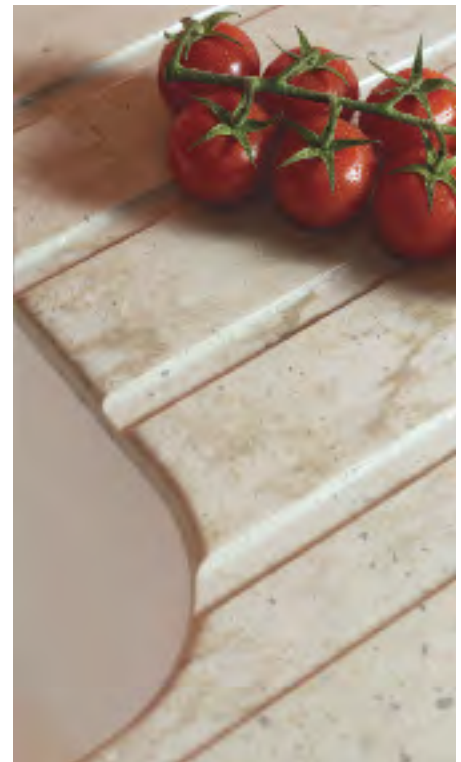

Drainer grooves can be graduated within the solid surface from 2mm – 5mm to create a water fall that drains away drips and splashes.

SINKS AND BOWLS WITH STAINLESS STEEL BASES



CTK0162

Base Options:
Colour Matched / Stainless Steel

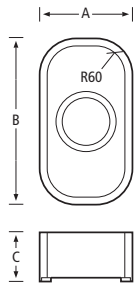

- A 162mm
- B 300mm
- C 95mm



CTK0375

Base Options:
Colour Matched / Stainless Steel

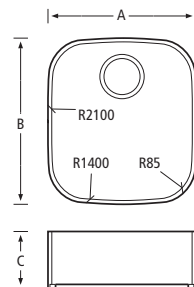

- A 375mm
- B 420mm
- C 150mm



CTK0332

Base Options:
Colour Matched / Stainless Steel

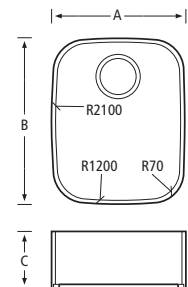

- A 332mm
- B 418mm
- C 150mm



CTK0400

Base Options:
Colour Matched / Stainless Steel

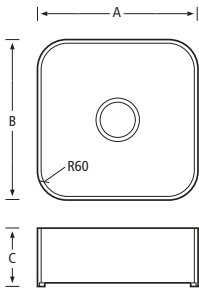

- A 400mm
- B 400mm
- C 150mm



CTK0450

Base Options:
Colour Matched / Stainless Steel

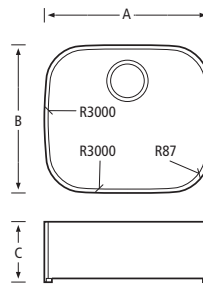

- A 450mm
- B 400mm
- C 150mm



CTK0495

Base Options:
Colour Matched / Stainless Steel

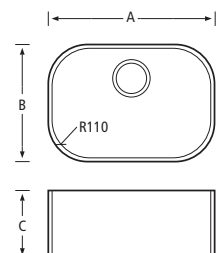

- A 495mm
- B 345mm
- C 150mm



CTK0550

Base Options:
Colour Matched / Stainless Steel

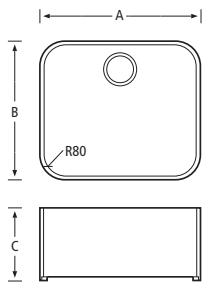

-
- A 162mm
 - B 300mm
 - C 95mm
-



TK0199

Base Options:
Colour Matched / Stainless Steel

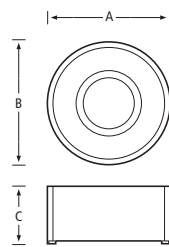

-
- A 199mm
 - B 199mm
 - C 100mm
-



TK0385

Base Options:
Colour Matched / Stainless Steel

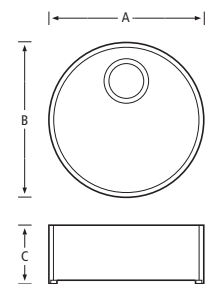

-
- A 385mm
 - B 385mm
 - C 150mm
-



SPECIALLY ORDERED SINKS AND BOWLS

Staron sinks and bowls can also be formed using any of the Staron designs available in the UK and Ireland.

These specially ordered sinks can either colour match or contrast with the surrounding Staron surfaces into which they can be seamlessly installed.

STAINLESS STEEL UNDERMOUNT SINKS



ESK
0.5 bowl / Stainless Steel

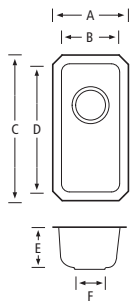

A	230mm	D	400mm
B	180mm	E	124mm
C	450mm	F	90mm



WEAVER
1.0 bowl / Stainless Steel

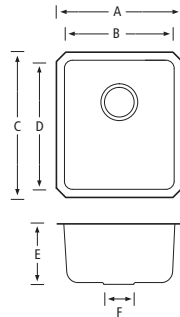

A	390mm	D	400mm
B	340mm	E	195mm
C	450mm	F	90mm



TWISS
1.0 bowl / Stainless Steel

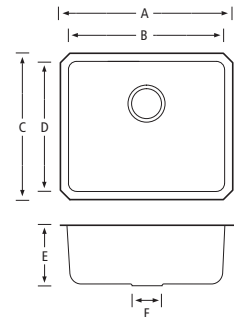

A	530mm	D	400mm
B	480mm	E	200mm
C	450mm	F	90mm



The high grade 18/10 stainless steel of these undermount sinks ensures a quality finish and long term corrosion resistance.



BRETT
1.5 bowl / Stainless Steel

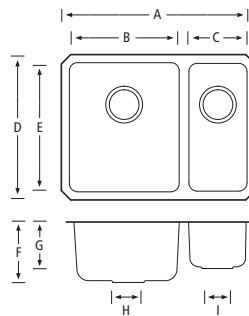

A	600mm	F	184mm
B	340mm	G	124mm
C	180mm	H	90mm
D	450mm	I	90mm
E	400mm		



TRENT
1.5 bowl / Stainless Steel

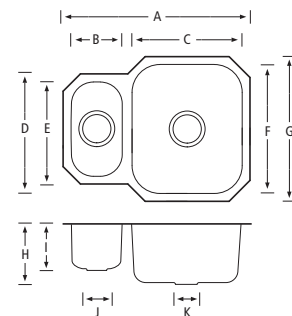

A	594mm	G	460mm
B	164mm	H	185mm
C	350mm	I	114mm
D	300mm	J	90mm
E	350mm	K	90mm
F	410mm		



COLNE

1.5 bowl / Stainless Steel

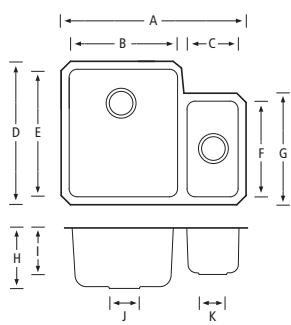

A	580mm	G	300mm
B	340mm	H	190mm
C	160mm	I	120mm
D	450mm	J	90mm
E	400mm	K	90mm
F	250mm		



DERWENT

1.5 bowl / Stainless Steel

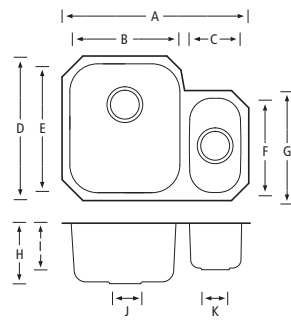

A	594mm	G	350mm
B	350mm	H	189mm
C	164mm	I	114mm
D	460mm	J	90mm
E	410mm	K	90mm
F	300mm		





STARON COLOUR	CODE	6mm SHEET 2500 x 760mm	12.3mm SHEET 3680 x 760mm	12.3mm SHEET 1840 x 760mm	CERTIFICATIONS SCS FR EURO CLASS
ASPEN BROWN	AB 632	-	•	•	B
ASPEN FIESTA	AF 611	-	•	•	- B
ASPEN GLACIER	AG 612	•	•	•	- C
ASPEN LAVA	AL 650	-	•	•	- B
ASPEN MINE	AM 633	-	•	•	C
ASPEN PEPPER	AP 640	-	•	•	B
ASPEN SKY	AS 670	-	•	•	- B
ASPEN SNOW	AS 610	-	•	•	C
EATHERN BARK	QL 257	-	•	•	- B
EATHERN STRATUM	QL 287	-	•	•	- B
METALLIC GALAXY	EG 595	-	•	•	- C
METALLIC SLEEK SILVER	ES 581	-	•	•	- B
METALLIC YUKON	EY 510	-	•	•	- C
PEBBLE BLUE	PB 870	-	•	•	C
PEBBLE CHIFFON	PC 842	-	•	•	- B
PEBBLE EBONY	PE 814	-	•	•	B
PEBBLE GOLD	PG 840	-	•	•	C
PEBBLE GREY	PG 810	-	•	•	- C
PEBBLE ICE	PI 811	-	•	•	- C
PEBBLE SARATOGA	PS 820	-	•	•	C
PEBBLE SWAN	PS 813	-	•	•	- C
PEBBLE TERRAIN	PT 857	-	•	•	- C
QUARRY MINETTE	QM 289	-	•	•	- B
QUARRY OYSTER	TO 310	-	•	•	C
QUARRY STARRED	QS 287	-	•	•	- B
SANDED BIRCH	SB 412	-	•	•	- B
SANDED CORNMEAL	SC 433	-	•	•	- C
SANDED CLAY	SC 475	-	•	•	- B
SANDED CREAM	SM 421	-	•	•	C
SANDED DARK NEBULA	DN 421	-	•	•	C
SANDED DOVER	SD 413	-	•	•	- B
SANDED GOLD DUST	SG 441	-	•	•	B
SANDED GREY	SG 420	-	•	•	C
SANDED HERON	SH 428	-	•	•	- B
SANDED ICICLE	SI 414	-	•	•	- C
SANDED MOCHA	SM 453	-	•	•	B
SANDED OATMEAL	SO 446	-	•	•	- C
SANDED ONYX	SO 423	•	•	•	B
SANDED PAPYRUS	SP 474	-	•	•	- C
SANDED SAHARA	SS 440	-	•	•	B
SANDED STRATUS	SS 418	-	•	•	- B
SANDED TUNDRA	ST 482	-	•	•	- C
SANDED VERMILLION	SV 430	-	•	•	B
SOLID BRIGHT WHITE	BW 010	•	•	•	- C

STARON COLOUR	CODE	6mm SHEET 2500 x 760mm			12.3mm SHEET 3680 x 760mm		12.3mm SHEET 1840 x 760mm		CERTIFICATIONS	
		SCS	FR	EURO CLASS	SCS	FR	EURO CLASS	SCS	FR	EURO CLASS
SOLID FOG	SF 020	-			•		•	-		C
SOLID IVORY	SI 040	-			•		•	-		C
SOLID NATURAL	SV 041	-			•		•	-		C
SOLID PEARL	SP 011	•			•		•	-		C
SOLID PURE WHITE	SP 016	-			•		•	-		C
SOLID QUASAR WHITE	SQ 019	•			•		•	-		C
SUPER SOLID BERRY FROST	SB 033	-			•		•	-		C
SUPER SOLID BLIS	SB 022	-			•		•	-		B
SUPER SOLID CALIFORNIA POPPY	SC 052	-			•		•	-		C
SUPER SOLID COOL MINT	SC 063	-			•		•	-		C
SUPER SOLID DAZZLING WHITE	SD 001	-			•		•	-		C
SUPER SOLID EGGPLANT	SV 037	-			•		•	-		B
SUPER SOLID IRIS	SI 056	-			•		•	-		C
SUPER SOLID ONYX	ON 095	•			•		•	-		C
SUPER SOLID PLACID	SP 062	-			•		•	-		B
SUPER SOLID POWDER BLUE	SP 063	-			•		•	-		C
SUPER SOLID SERENE	SS 023	-			•		•	-		B
SUPER SOLID STEEL	ST 023	-			•		•	-		C
SUPER SOLID SUNFLOWER	SS 042	-			•		•	-		C
SUPER SOLID TUSK	ST 015	-			•		•	-		C
SUPER SOLID UNIVERS	SU 053	-			•		•	-		C
SUPREME CLOUDBANK	VC 118	-			•		•	-		X
SUPREME DANDELION	VD 175	-			•		•	-		X
SUPREME DAWN	VD 126	-			•		•	-		X
SUPREME DELPHI	VD 111	-			•		•	-		X
SUPREME LOAM	VL 155	-			•		•	-		X
SUPREME MAGNOLIA	VM 143	-			•		•	-		X
SUPREME NATURAL BRIDGE	VN 144	-			•		•	-		X
SUPREME PASTORAL	VP 177	-			•		•	-		X
TEMPEST BLAZE	FB 147	-			•		•	-		C
TEMPEST CAVIAR	FC 188	-			•		•	-		C
TEMPEST DAZZLE	FD 191	-			•		•	-		C
TEMPEST GENESIS	FG 174	-			•		•	-		C
TEMPEST GLIMMER	FG 144	-			•		•	-		C
TEMPEST HORIZON	FH 114	-			•		•	-		C
TEMPEST METEOR	FM 111	-			•		•	-		C
TEMPEST PEAK	FP 100	-			•		•	-		C
TEMPEST POLAR	FP 111	-			•		•	-		C
TEMPEST RADIANCE	FR 148	-			•		•	-		C
TEMPEST RATTAN	FR 124	-			•		•	-		C
TEMPEST SILVERCLOUD	FS 122	-			•		•	-		C
TEMPEST STARFIRE	FS 198	-			•		•	-		C
TEMPEST WHIPPOORWILL	FW145	-			•		•	-		C
TEMPEST ZENITH	FZ 184	-			•		•	-		C

MAKE AN IMPRESSION WITH A NEW STANDARD OF DESIGNS

Taking inspiration from pure nature and unique designs are the major features of these eight designs in the Supreme™ Collection.



SUPREME DELPHI VD 111



SUPREME DAWN VD 126

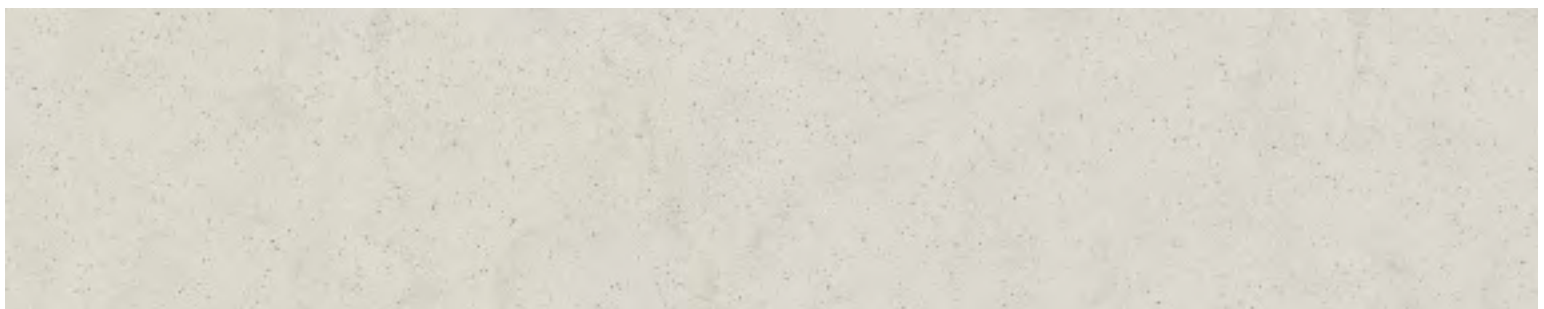

SUPREME NATURAL BRIDGE VN 144

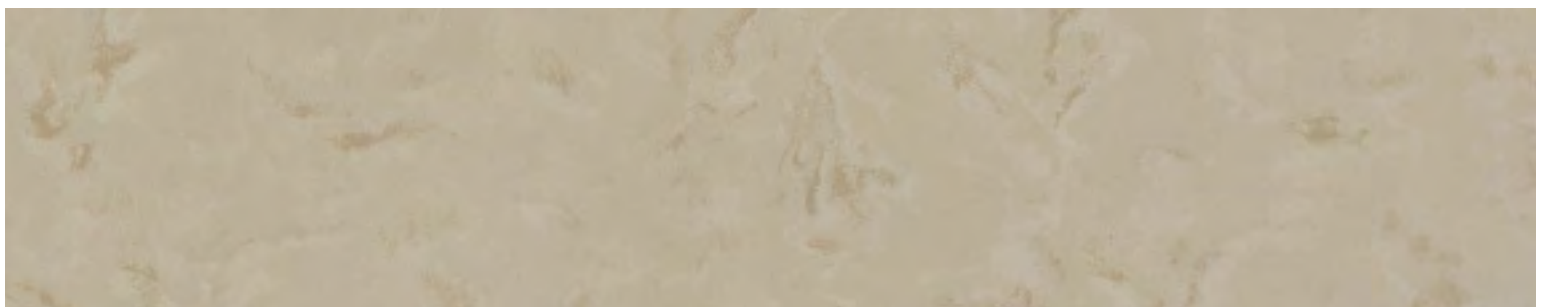

SUPREME PASTORAL VP 177

Whilst every effort has been made to accurately represent the décors within this brochure, we are unable to guarantee an exact match due to the limitations of the printing process. Please view actual sample prior to selection.

Darker colours in the Staron range are more delicate than lighter colours and require a greater level of care.

Before you install your Staron surface, please verify that batch numbers are the same to ensure a complete colour match.

❖ These colours may require additional maintenance.

Supreme

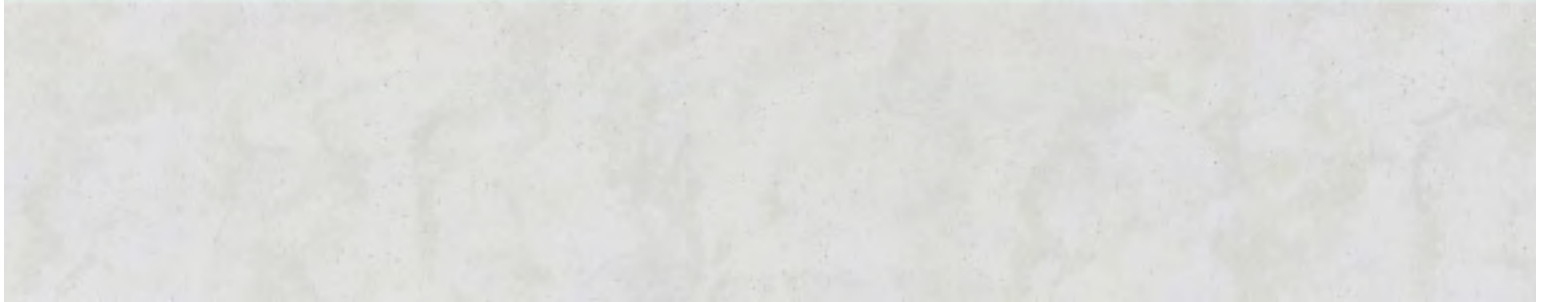

SUPREME CLOUDBANK VC 118

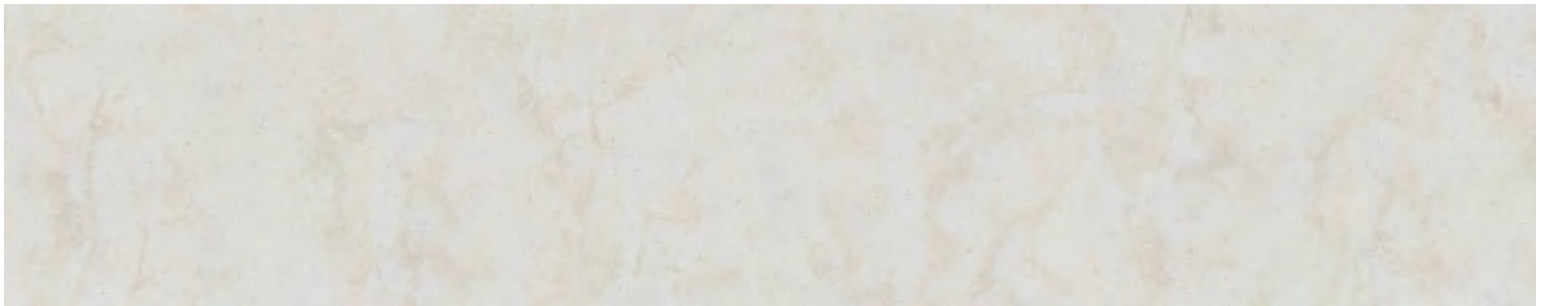

SUPREME MAGNOLIA VM 143

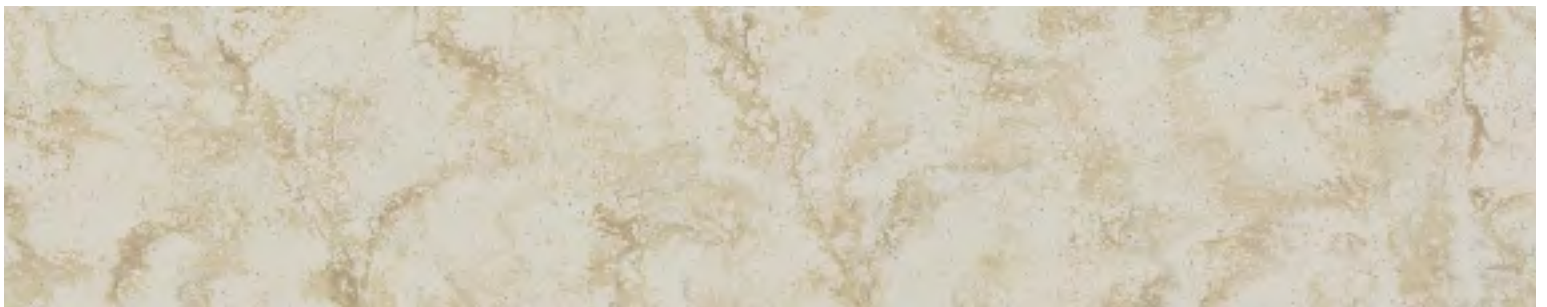

SUPREME DANDELION VD 175

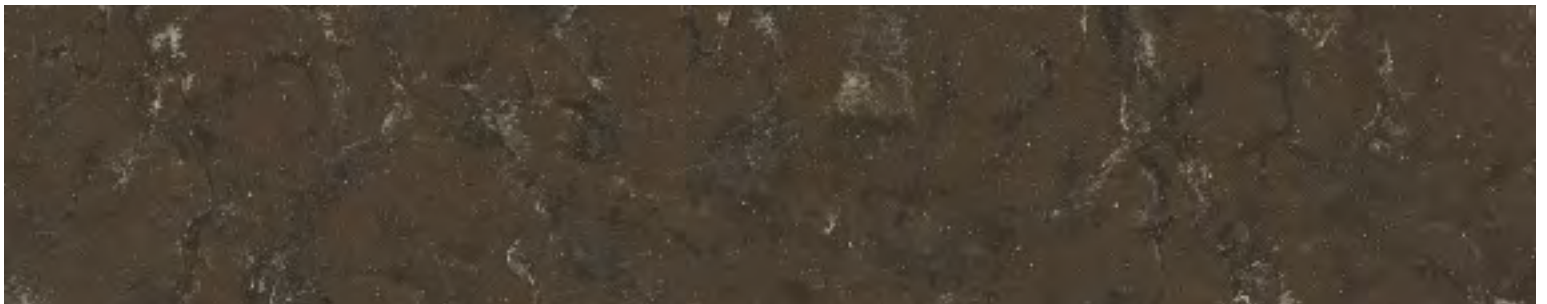

SUPREME LOAM VL 155

SAMPLES

Blackheath Products has invested heavily in Staron and has cases of samples which are available on request. A library of larger samples is also available.

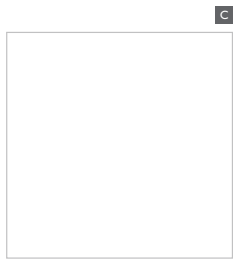

SOLID PURE WHITE
SP 016

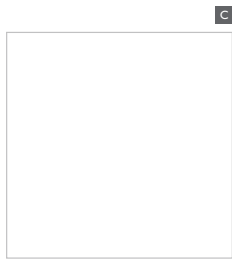

SOLID QUASAR WHITE
SQ 019



SOLID BRIGHT WHITE
BW 010



SOLID PEARL
SP 011

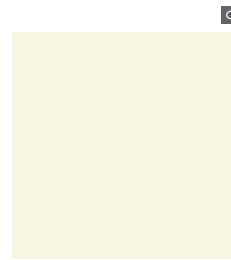

SOLID NATURAL
SV 041

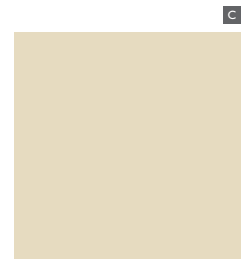

SOLID IVORY
SI 040

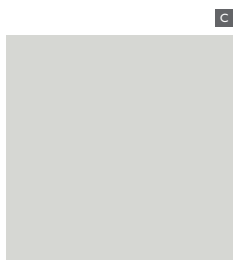

SOLID FOG
SF 020

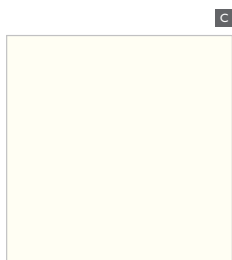

**SUPER SOLID
DAZZLING WHITE
(TRANSLUCENT)**
SD 001

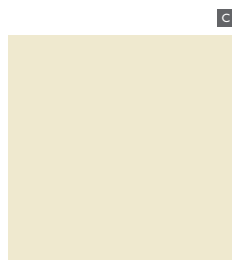

**SUPER SOLID
TUSK**
ST 015

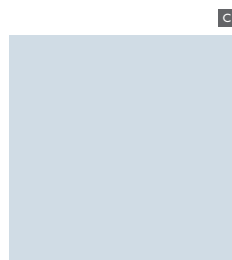

**SUPER SOLID
POWDER BLUE**
SP 063

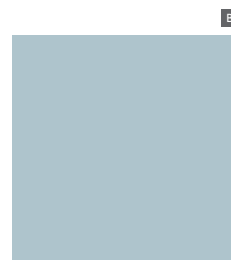

**SUPER SOLID
PLACID**
SP 062

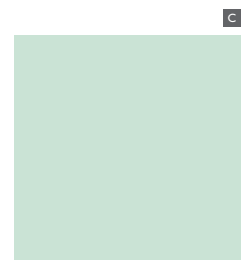

**SUPER SOLID
COOL MINT**
SC 063

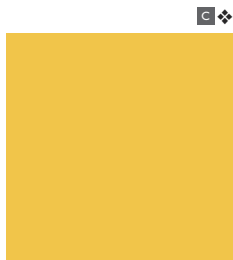

**SUPER SOLID
SUNFLOWER**
SS 042



**SUPER SOLID
CALIFORNIA POPPY**
SC 052

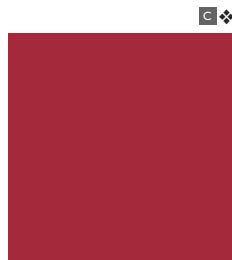

**SUPER SOLID
UNIVERS**
SU 053

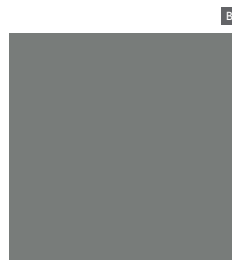

**SUPER SOLID
BLIS**
SB 022

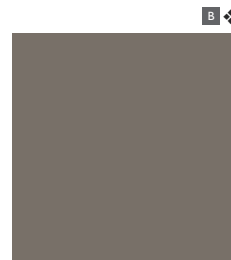

**SUPER SOLID
SERENE**
SS 023

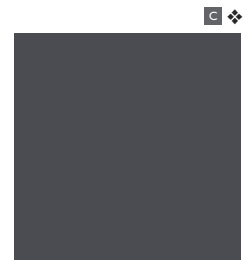

**SUPER SOLID
STEEL**
ST 023

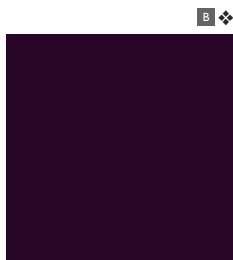

**SUPER SOLID
EGGPLANT**
SV 037

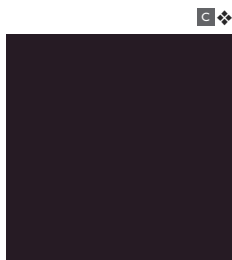

**SUPER SOLID
IRIS**
SI 056

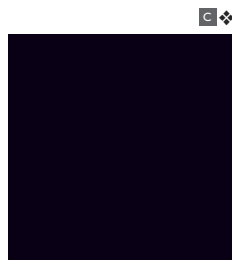

**SUPER SOLID
ONYX**
ON 095

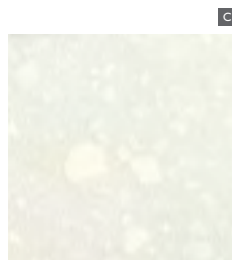

PEBBLE ICE
PI 811

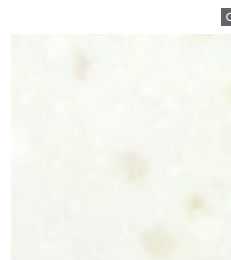

PEBBLE SWAN
PS 813



PEBBLE SARATOGA
PS 820



PEBBLE CHIFFON
PC 842

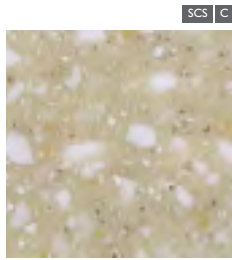

PEBBLE GOLD
PG 840

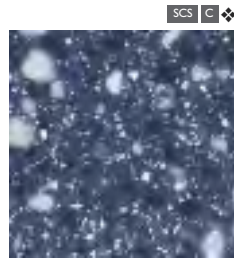

PEBBLE BLUE
PB 870

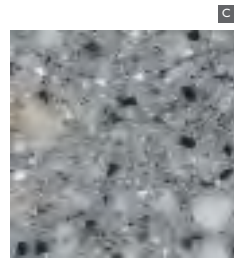

PEBBLE GREY
PG 810

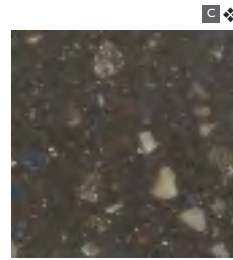

PEBBLE TERRAIN
PT 857

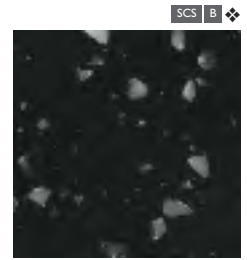

PEBBLE EBONY
PE 814

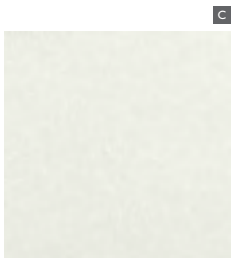

SANDED ICICLE
SI 414

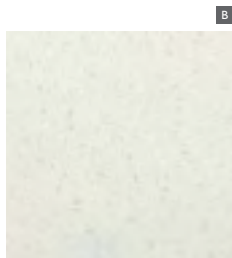

SANDED DOVER
SD 413

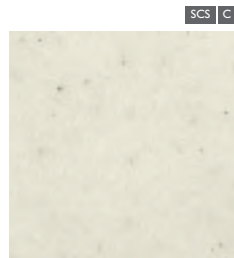

SANDED CREAM
SM 421

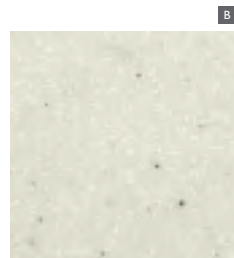

SANDED BIRCH
SB 412

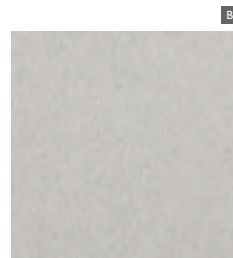

SANDED STRATUS
SS 418



SANDED SAHARA
SS 440

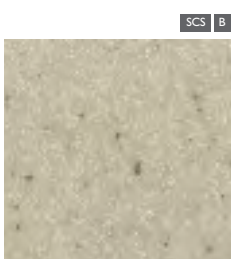

SANDED GOLD DUST
SG 441

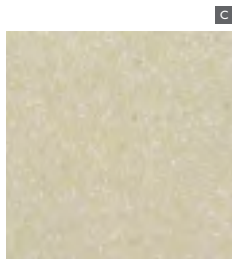

SANDED CORNMEAL
SC 433

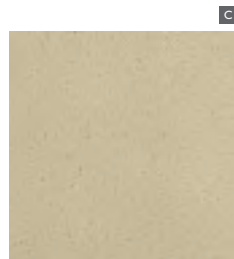

SANDED PAPYRUS
SP 474

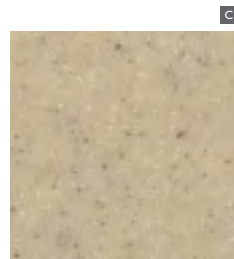

SANDED OATMEAL
SO 446

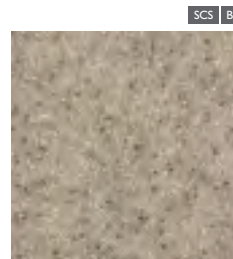

SANDED VERMILLION
SV 430



SANDED GREY
SG 420



SANDED MOCHA
SM 453

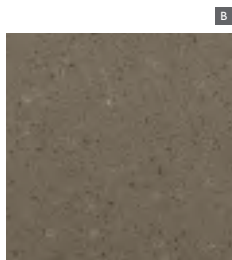

SANDED CLAY
SC 475



SANDED HERON
SH 428

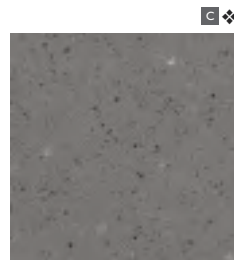

SANDED TUNDRA
ST 482

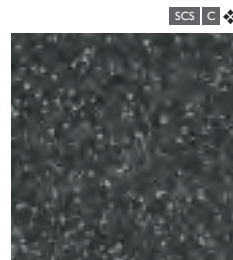

SANDED DARK NEBULA
DN 421

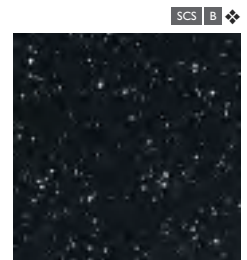

SANDED ONYX
SO 423

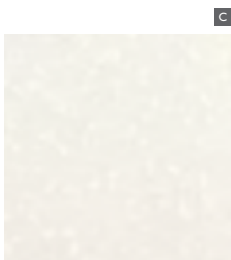

ASPEN GLACIER
AG 612

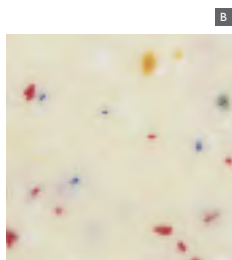

ASPEN FIESTA
AF 611

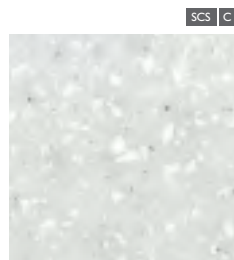

ASPEN SNOW
AS 610



ASPEN PEPPER
AP 640

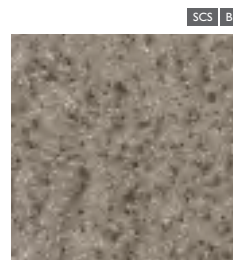

ASPEN BROWN
AB 632

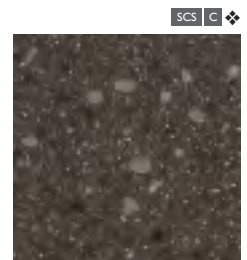

ASPEN MINE
AM 633



ASPEN LAVA
AL 650

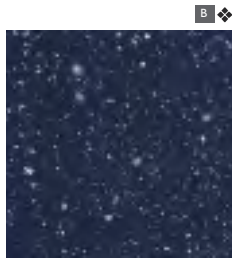

ASPEN SKY
AS 670

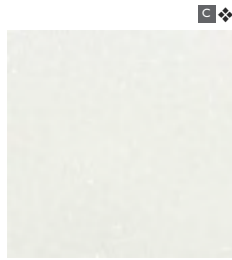

METALLIC YUKON
EY 510

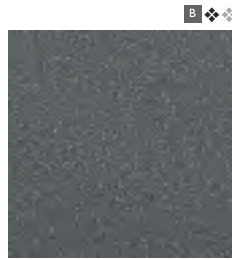

METALLIC SLEEK SILVER
ES 581

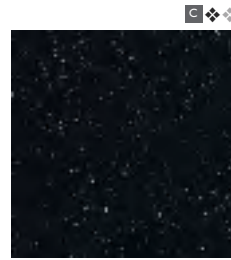

METALLIC GALAXY
EG 595

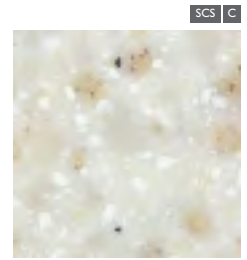

QUARRY OYSTER
TO 310



QUARRY STARRED
QS 287



QUARRY MINETTE
QM 289

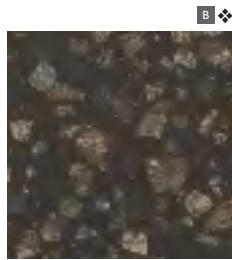

EARTHERN BARK
QL 257

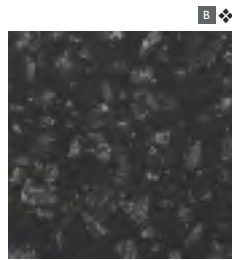

EARTHERN STRATUM
QL 287

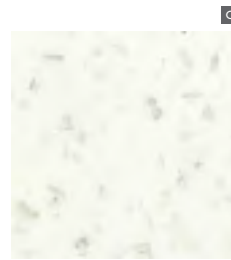

TEMPEST PEAK
FP 100

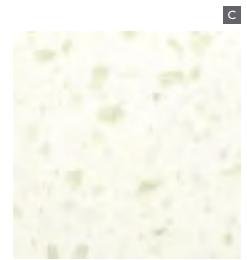

TEMPEST POLAR
FP 111

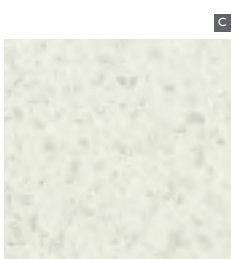

TEMPEST METEOR
FM 111



TEMPEST HORIZON
FH 114

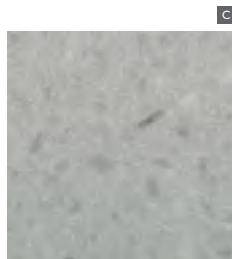

TEMPEST SILVERCLOUD
FS 122

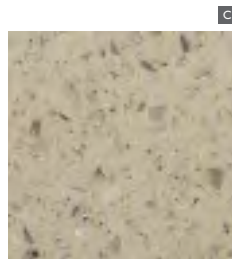

TEMPEST GENESIS
FG 174

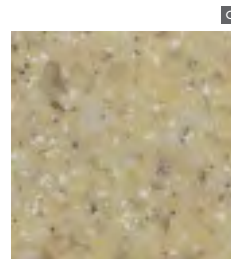

TEMPEST RATTAN
FR 124

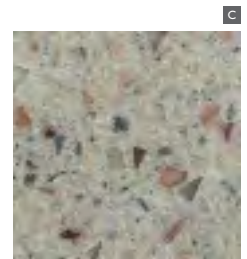

TEMPEST GLIMMER
FG 144

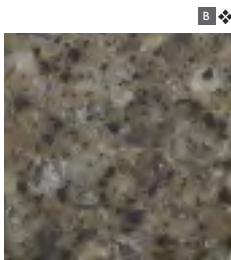

TEMPEST WHIPPOORWILL
FW 145

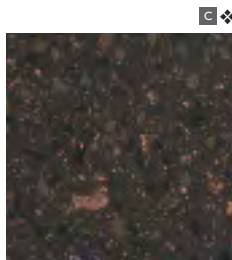

TEMPEST BLAZE
FB 147

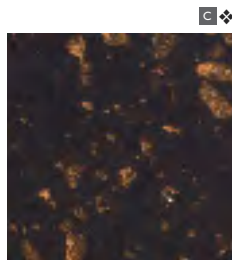

TEMPEST RADIANCE
FR 148

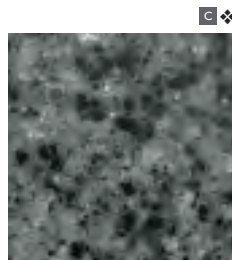

TEMPEST ZENITH
FZ 184

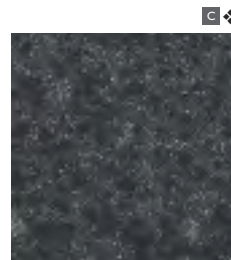

TEMPEST CAVIAR
FC 188

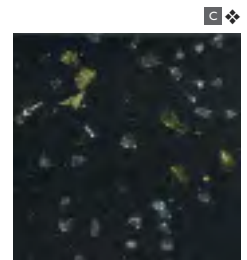

TEMPEST DAZZLE
FD 191

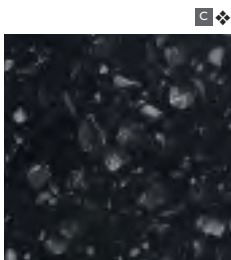

TEMPEST STARFIRE
FS 198

SCS These colours hold the SCS Material Content Certification which verifies that Staron is working responsibly to minimise environmental impact during its manufacturing process.

B European FR 'Class B' Certification. **C** European FR 'Class C' Certification.

❖ These colours may require additional maintenance.

❖ Contains metallic flakes that have reflective properties, which may cause the colour to look different (brightness) depending on the angle of view.

Whilst every effort has been made to accurately represent the décors within this brochure, we are unable to guarantee an exact match due to the limitations of the printing process. Please view actual sample prior to selection.

Darker colours in the Staron range are more delicate than lighter colours and require a greater level of care.

Before you install your Staron surface, please verify that batch numbers are the same to ensure a complete colour match.

ENVIRONMENTAL

For designers seeking green credentials, Staron's recycled range holds the SCS Material Content Certification which verifies that Staron is working responsibly to minimise environmental impact during its manufacturing process.



Staron's capacity to be repaired in the unlikely event of damage caused by a serious impact is an environmental benefit. Alternative surfacing materials that have been damaged cannot be repaired and are then often wastefully scrapped.

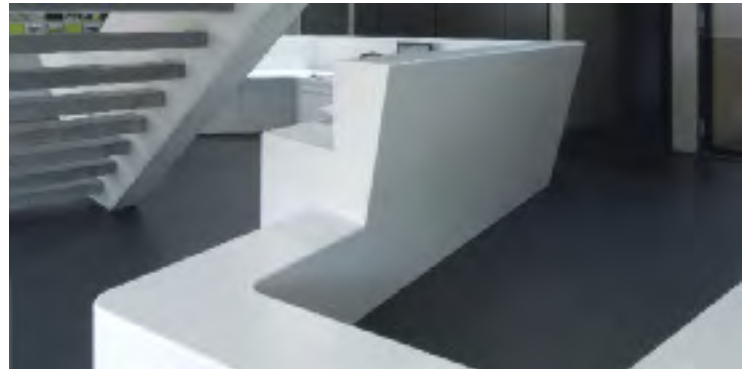

ASPEN BROWN
AB 632



ASPEN MINE
AM 633



ASPEN SNOW
AS 610



ASPEN PEPPER
AP 640

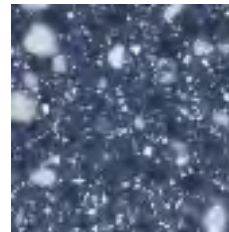

PEBBLE BLUE
PB 870

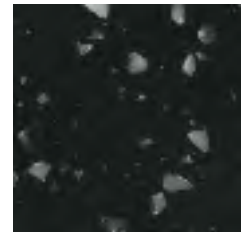

PEBBLE EBONY
PE 814

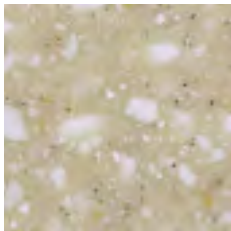

PEBBLE GOLD
PG 840



PEBBLE SARATOGA
PS 820



QUARRY OYSTER
TO 310

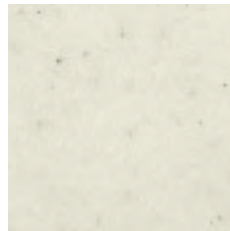

SANDED CREAM
SM 421



SANDED DARK NEBULA
DN 421



SANDED GOLD DUST
SG 441



SANDED GREY
SG 420



SANDED MOCHA
SM 453



SANDED ONYX
SO 423



SANDED SAHARA
SS 440

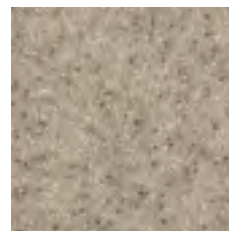

SANDED VERMILLION
SV 430

A glass of blueberries is shown on a dark, textured surface. The blueberries are fresh and covered in water droplets. The background is a dark, speckled material, likely a solid surface product.

staron[®]

Solid Surfaces

**BLACKHEATH PRODUCTS LIMITED
EXCLUSIVE UK AND IRELAND
STARON DISTRIBUTOR**

Units 1-4 Fairfield Park,
Halesowen, West Midlands B62 9JL

Free 24 hour faxline: 0800 634 0114

Telephone: 0121 561 3939

Email: sheets@blackheathproducts.co.uk

www.staron.uk.com

blackheath 

Blackheath Products Limited has over 50 years experience in the distribution of decorative sheet materials and components to the construction industry. All Staron designs featured in this brochure are available for immediate delivery by Blackheath Products fleet of 26 commercial vehicles from its centrally located distribution centre.

We reserve the right to update specifications without notice. Staron[®] is a registered trade mark of Lotte Chemical Corporation. E&OE. All dimensions shown are nominal.